

SDSD.0076 SharpDrain Square DATA SHEET

Minimum floor depth (76mm) square drain which can be installed anywhere in a wetroom or be used as secondary drainage. Perfect for areas that have little floor depth available. Panels and tile inserts are available as Brushed Stainless Steel or PVD coated colours.



Model No.	Structural Length	Visual Length	Drain Depth	Frame & Grate Kit Order Ref	Steel Panel Kit Order Ref	Black Panel Kit Order Ref	Brass Panel Kit Order Ref	Nickel Panel Kit Order Ref	Bronze Panel Kit Order Ref
76	197	145 x 145	76	SDSD.0076FG	SDSD.0076SS	SDSD.0076BL	SDSD.0076BS	SDSD.0076NI	SDSD.0076BZ

Side View

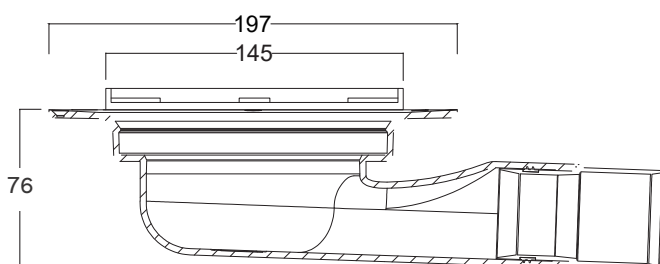

Plan View

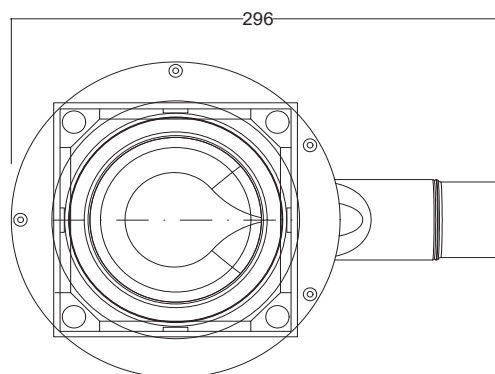

Specification

MATERIAL Plastic (PP), Solvent Weld ABS Adapter	CAPACITY 48 l/min	TRAP Removable anti odour trap
USAGE Wetroom and secondary drainage	MEMBRANE Liquid or sheet membrane	FLOOR CONSTRUCTION All