

## SDSD.0189 SharpDrain Square Vertical DATA SHEET

A vertical drain with an overall depth 230mm, which can be installed anywhere in a wetroom or be used as secondary drainage. Perfect for projects that require a slim drain. Change a slim drain to a vertical connection. Panel and Tile Inserts are available as Brushed Stainless Steel or PVD coated colours.

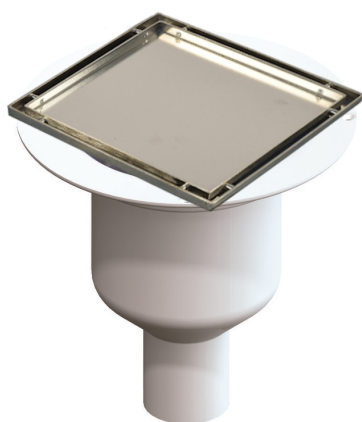

Plan View

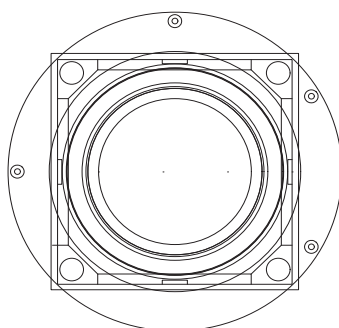

Side View

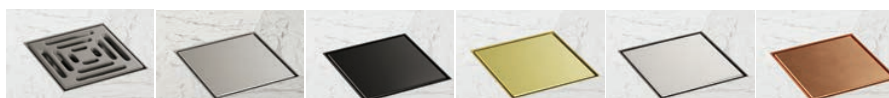
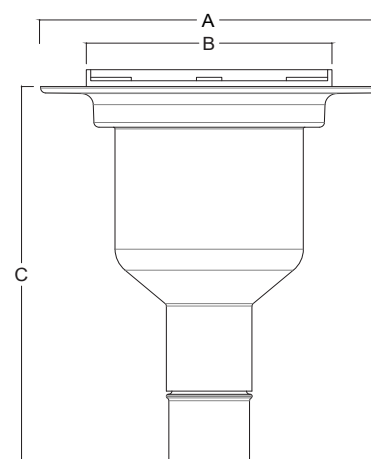

Model No.	Structural Length (A)	Visual Length (B)	Drain Depth (C)	Frame & Grate Kit Order Ref	Steel Panel Kit Order Ref	Black Panel Kit Order Ref	Brass Panel Kit Order Ref	Nickel Panel Kit Order Ref	Bronze Panel Kit Order Ref
189	197	145 x 145	230	SDSD.0189FG	SDSD.0189SS	SDSD.0189BL	SDSD.0189BS	SDSD.0189NI	SDSD.0189BZ



Model No.	Structural Length (A)	Visual Length (B)	Drain Depth (C)	Steel Tile Insert Kit Order Ref	Black Tile Insert Kit Order Ref	Brass Tile Insert Kit Order Ref	Nickel Tile Insert Kit Order Ref	Bronze Tile Insert Kit Order Ref
189	197	145 x 145	230	SDSD.0189SS	SDSD.0189BL	SDSD.0189BS	SDSD.0189NI	SDSD.0189BZ

### Specification

<b>MATERIAL</b> Plastic (PP), Solvent Weld ABS Adapter	<b>CAPACITY</b> 48 l/min	<b>TRAP</b> Removable anti odour trap
<b>USAGE</b> Wet Room and secondary drainage	<b>MEMBRANE</b> Liquid, sheet membrane	<b>FLOOR CONSTRUCTION</b> All