

SDTL.1000 TILE LINE

Low profile (72mm) linear drain with a 50mm water seal. Perfect for wet rooms that have a shallow floor depth. Tile Line allows you to glue a tile into the drain with no visible metal. Factory fitted membrane for added waterproof protection.



Specifications

MATERIAL

1.25 mm stainless steel (316)
PP (Plastic) 1 1/2" solvent weld adapter

USAGE

Linear drain

WATER TRAP HEIGHT

50mm

GRATING

Brushed Stainless Steel panel tile insert.

MEMBRANE

330mm factory fitted sheet membrane

REMOVABLE & EASY FOR CLEANING

50mm

CAPACITY

32 l/min

FLOORING

Tiles

SDTL.1000

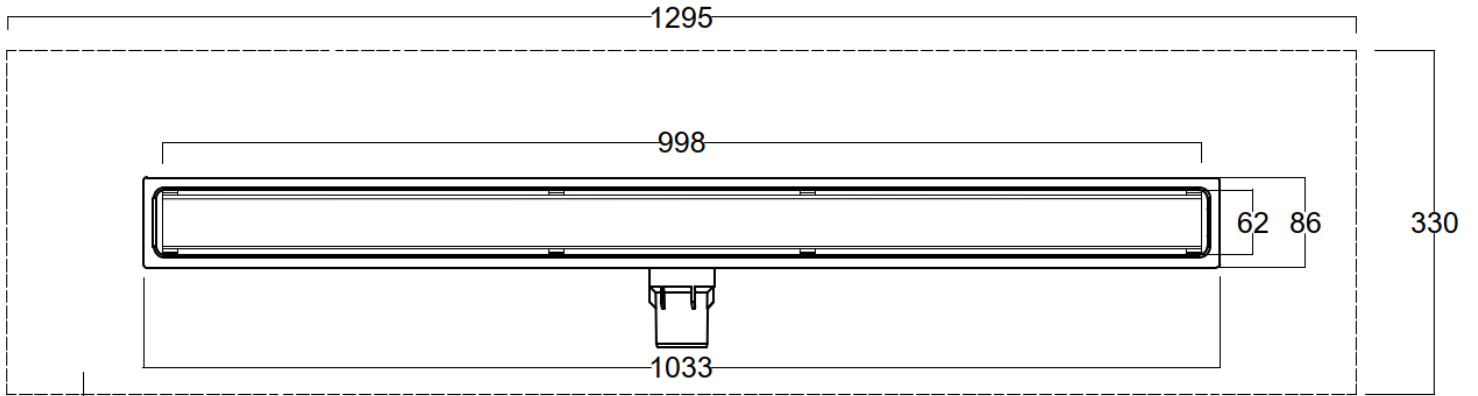

Factory Fitted Membrane

Plan

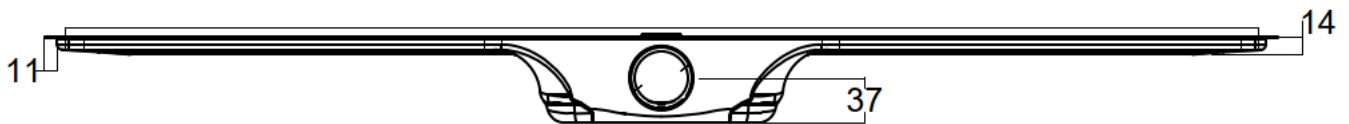

Front

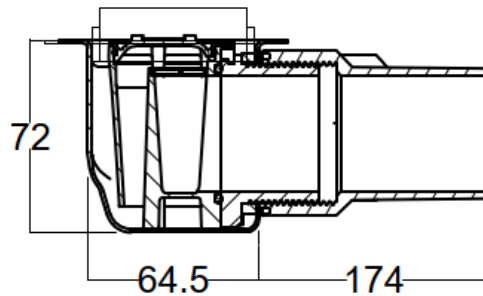

Side