

# SharpDrain® Pro | Linear

## Tile Insert / Panel

### PSDTP.1200

New and improved SharpDrain with 360 rotating offset outlet for tricky joists and easy connection. The drain can be rotated to have the outlet offset on the opposite site. Factory fitted membrane for added waterproof protection. Available as Brushed Panel or Steel Tile Insert.

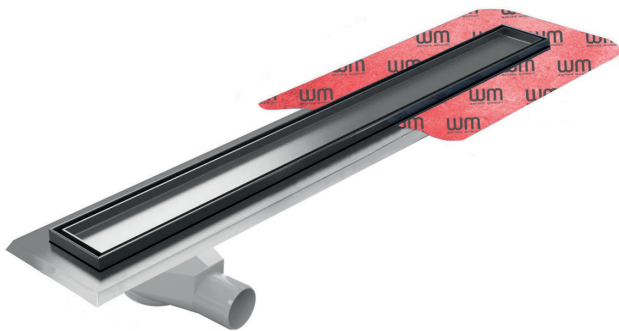

## Specification

<b>MATERIAL</b>	<b>GRATING</b>	<b>CAPACITY</b>
Stainless Steel and Plastic	Brushed Stainless Steel Panel and Tile Insert	48 l/min
<b>USAGE</b>	<b>MEMBRANE</b>	<b>FLOORING</b>
Linear Drain	Factory Fitted Membrane	Tiles
<b>WATER TRAP HEIGHT</b>	<b>REMOVABLE TRAP FOR CLEANING</b>	<b>OUTLET</b>
50mm	Yes	360° Rotating Outlet

# SharpDrain® Pro | Linear

## Tile Insert / Panel

PSDTP.1200

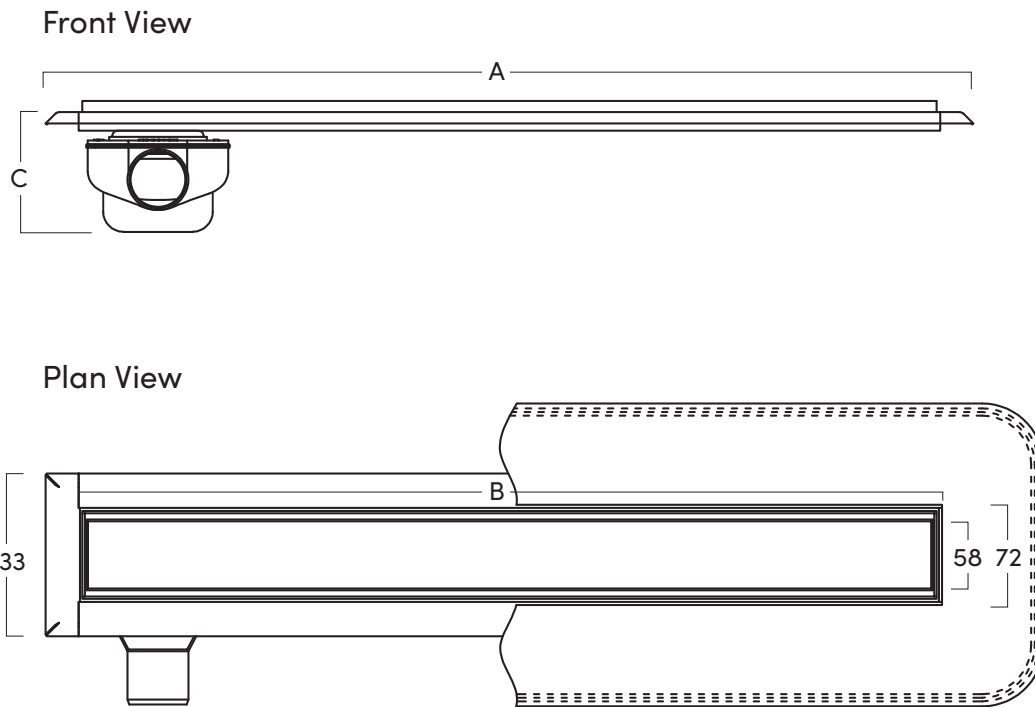

STRUCTURAL LENGTH - A

1260mm

VISUAL LENGTH - B

1200mm

DRAIN DEPTH - C

99mm

Refer to technical drawings for more information.