

## KIT CONTAINS

WALL MOUNTED  
CORNER DRAIN  
STANDARD OUTLET  
HIGHLINE CUSTOM

## 2951.0200

Highline Custom corner incl. drain | 2951

The set consists of a Custom corner drain unit, Custom corner panel, spacers and glue.

Fits wall tiles in wall thickness 6-20 mm.

The recesses of the drain unit ensure correct positioning of the panel.

The glue provides optimum adhesion between panel and tile.



### Specifications

<b>ITEM NUMBER</b> 2951.0200	<b>GTIN NUMBER</b> 5707692012858	<b>WEIGHT INCLUDING PACKAGING</b> 1100 g
<b>WEIGHT EXCLUDING PACKAGING</b> 900 g	<b>MATERIAL</b> 1,5 mm stainless steel (AISI 304)	<b>USAGE</b> Corner drain
<b>SURFACE</b> Pickled	<b>MEMBRANE</b> Liquid or sheet membrane	<b>FLOOR CONSTRUCTION</b> All
<b>FLOORING</b> Tiles	<b>MOUNTING</b> 6 mm plugs 6 mm screws. Torx 20	<b>INSTALLATION LENGTH (L)</b> 377 x 267 mm

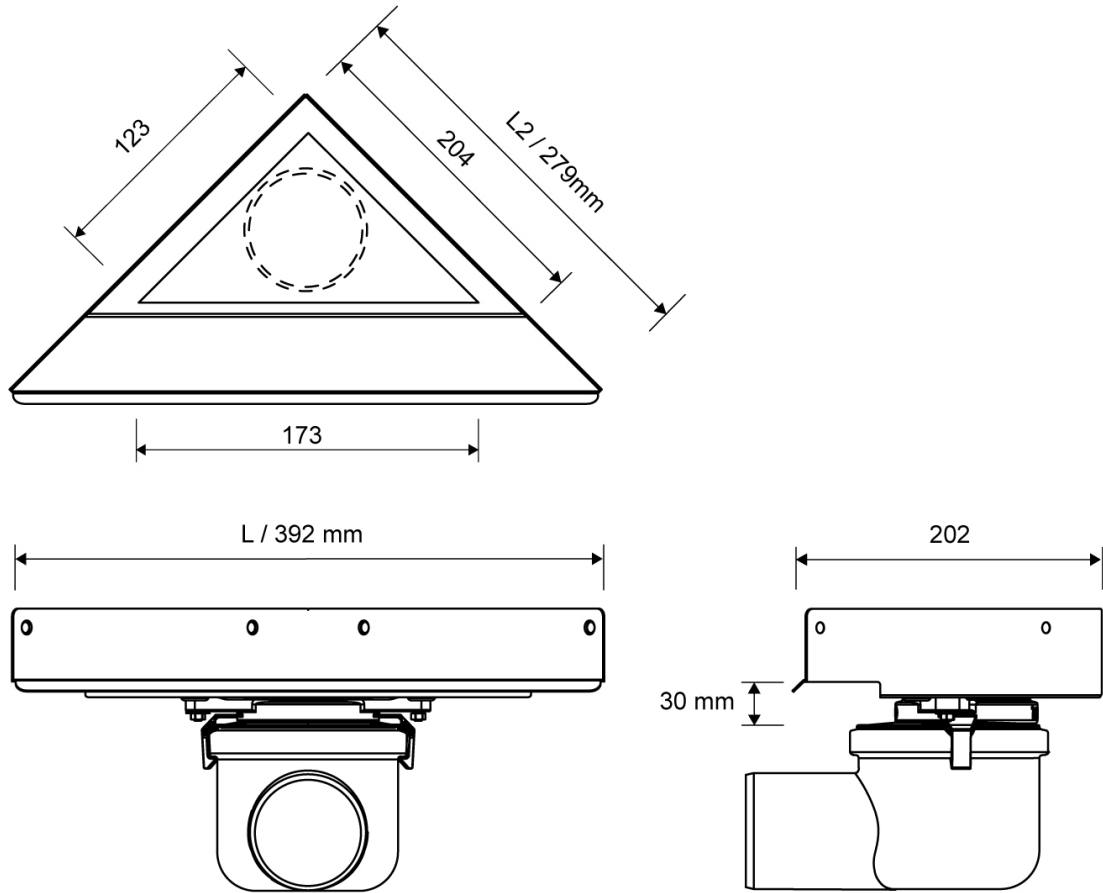

**2951.0200**

Products

## 2411.0050

Line 2411.0050

Ø 50 mm horizontal drain

With water trap that can be removed and separated for cleaning

Can be rotated 360 degrees to facilitate pipework positioning



### Specifications

ITEM NUMBER	GTIN NUMBER	WEIGHT INCLUDING PACKAGING
2411.0050	5707692006604	5000 g
WEIGHT EXCLUDING PACKAGING	MATERIAL	USAGE
4000 g	Plastic PP	Corner drain
BARRIER	GASKET	CAPACITY
with	EPDM	0.8 l/s
SIDE INLET	CONSTRUCTION HEIGHT (CORNER)	FITS DRAIN UNIT
Without	126 mm	2011.0200

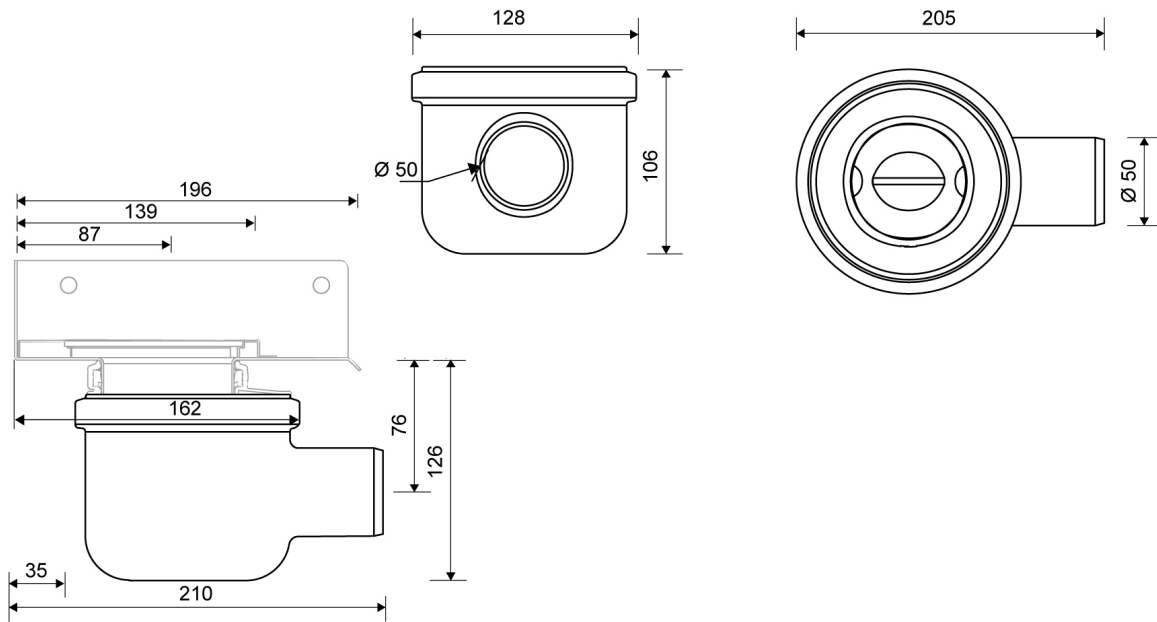

**2411.0050**

## 2950.0200

HighLine corner | CUSTOM

The set consists of a Custom base, rail, height adjusting set and screws. The set must be assembled before mounting. Can be installed with or without HighLine frame. Set includes 6 mm distance piece for use when mounting without a frame.



### Specifications

<b>ITEM NUMBER</b>	<b>GTIN NUMBER</b>	<b>WEIGHT INCLUDING PACKAGING</b>
2950.0200	5707692009384	400 g
<b>WEIGHT EXCLUDING PACKAGING</b>	<b>MATERIAL</b>	<b>USAGE</b>
300 g	Stainless steel (AISI 304)	Corner drain
<b>SURFACE</b>	<b>HEIGHTENER SET</b>	
Brushed	Plastic (PE)	

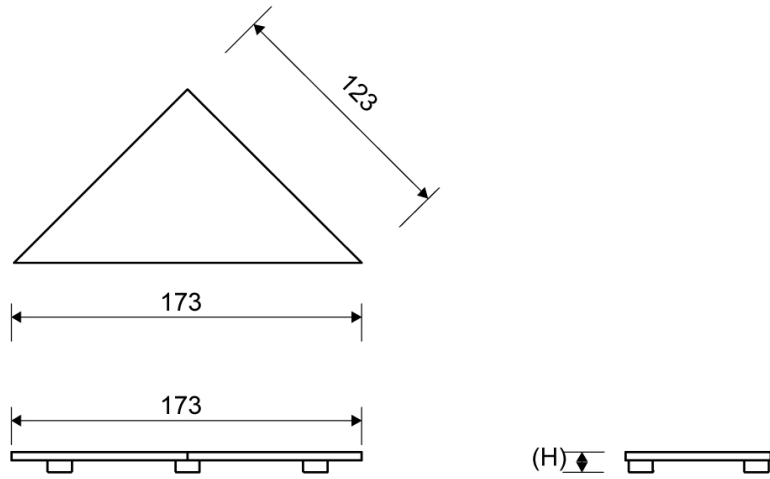

**2950.0200**